

A PART'N. WALL ROOF STRUCT.
SCALE: 1 1/2" = 1'-0"

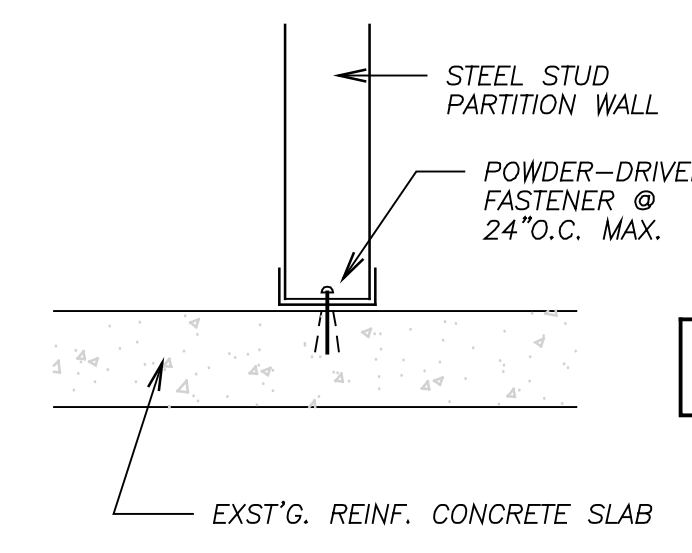

B PART'N. WALL @ FLOOR
SCALE: 1 1/2" = 1'-0"